

SignalCore™

PRESERVING SIGNAL INTEGRITY



Datasheet

SC5510B & SC5511B

80 MHz to 20 GHz CW Signal Source

Rev 2.1

www.signalcore.com

Table of Contents

| | | |
|----|---------------------------------------|----|
| 1. | Definition of Terms..... | 3 |
| 2. | Description..... | 4 |
| 3. | Port 1 Frequency Specifications | 5 |
| 4. | Port 1 Amplitude Specifications | 6 |
| 5. | Port 1 Spectral Specifications..... | 8 |
| 6. | Port 2 Specifications | 10 |
| 7. | General Specifications | 11 |
| 8. | Revision Table | 13 |

1. Definition of Terms

The following terms are used throughout this datasheet to define specific conditions:

| | |
|--------------------------------|---|
| Specification (spec) | Defines expected statistical performance within specified parameters which account for measurement uncertainties and changes in performance due to environmental conditions. Protected by warranty. |
| Typical Data (typ) | Defines the expected performance of an average unit without specified parameters. Not protected by warranty. |
| Nominal Values (nom) | Defines the average performance of a representative value for a given parameter. Not protected by warranty. |
| Measured Values (meas.) | Defines the expected product performance from the measured results gained from individual samples. |

Specifications are subject to change without notice. For the most recent product specifications, visit www.signalcore.com.

2. Description

The SC5510B and SC5511B are high performance VCO based synthesized signal sources with frequency range from 80 MHz to 20 GHz. The SC5510B is in the PXI single slot form-factor and the SC5511B is a compact module with USB and RS232 or SPI interfaces. Boasting low phase noise of -137 dBc/Hz @ 10 kHz offset from a 1 GHz carrier, tuning the entire band at 1 Hz resolution, and having amplitude step resolution of 0.01 dB over the range of < -20 dBm to $+15$ dBm set these products apart from other small modular synthesizers. Furthermore, using a unique multiple phase-locked loop architecture the phase spurs are typically kept below -65 dBc across the tuning range, even at 0.001 Hz step resolution. Furthermore, using a high fundamental frequency VCO (20 GHz) and eliminating multipliers, sub-harmonics due to dividers are typically less than -70 dBc and far out spurious signals are also kept below -70 dBc.

There is also an additional independent RF2 port whose frequency range covers 100 MHz to 3 GHz with tuning resolution of 25 MHz. This makes the modules ideal as local oscillators for both single-stage and dual-stage RF conversion systems. They are also great as general-purpose laboratory signal sources where demanding low phase noise and signal purity are needed, or ideal choices as integrated clock sources for fast DAC and ADC applications, especially those that require variable sampling rates.

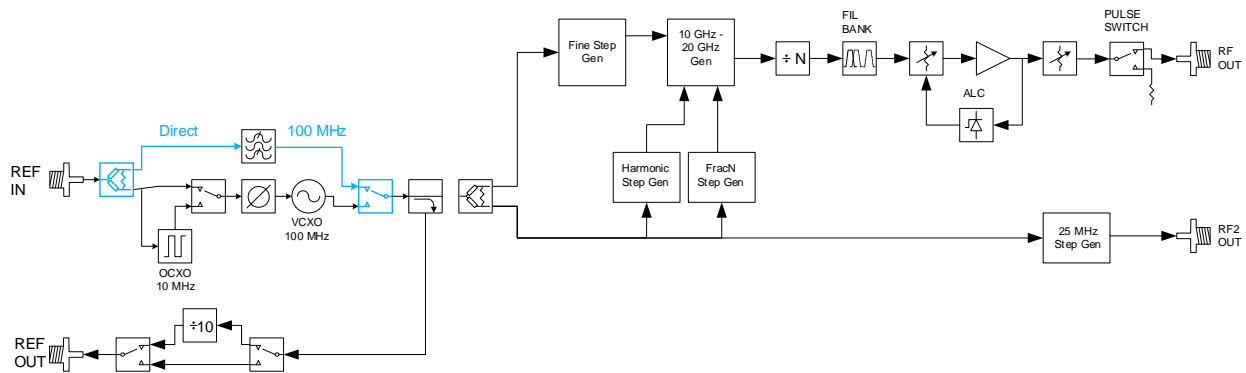

Figure 1. SC5510B/SC5511B Block Diagram

3. Port 1 Frequency Specifications⁴

| | | |
|--|--|---------------|
| RF Output Range ¹ | 100 MHz to 20 GHz | |
| Resolution | 0.001 Hz | |
| Switching speed | | |
| Automatic leveling on | 500 us | |
| Automatic leveling off | 350 us | |
| List Mode | | |
| Dwell time | 0.5ms to 30s | |
| Dwell step | 0.5ms | |
| Step points | 1024 | |
| Trigger | Software, External logic | |
| Frequency Accuracy | Same as accuracy of internal time base or external reference | |
| Time base accuracy ² | \pm [(last adjustment x aging) \pm temp effects \pm cal. accuracy] | |
| Aging | Daily, after 30 days | \pm 3 ppb |
| | Yearly | \pm 0.6 ppm |
| Temp effects | | \pm 20 ppb |
| Init cal. accuracy ³ | Calibration precision | \pm 200 ppb |
| Reference Output | | |
| Amplitude | 100 MHz | > 3 dBm |
| | 10 MHz | > 3 dBm |
| Reference Input | | |
| Frequency | 10 MHz/100 MHz | |
| Lock range | \pm 3 ppm | |
| Amplitude | (nominal) | 0 to 7 dBm |

¹ Tunes from 87.5 MHz to 21 GHz by design.

² Based on the internal 10 MHz OCXO reference, after 20 minutes of warmup.

³ Factory adjustment of the reference DAC with respect to a NIST traceable 10 MHz rubidium clock standard.

⁴ PXI: 27 \pm 5 °C ambient. Modular: 40 \pm 5 °C device temperature.

4. Port 1 Amplitude Specifications⁵

| | | |
|--|-------------------|-------------------------|
| Leveled Output Range ⁶ | 100 MHz to 18 GHz | -20 to +13 dBm |
| | 18 GHz to 20 GHz | -20 to +7 dBm |
| Maximum Output ⁷ | 100 MHz to 18 GHz | + 18 dBm, typical |
| | 18 GHz to 20 GHz | +13 dBm, typical |
| Adjustment resolution | | 0.01 dB, nominal |
| Absolute level accuracy | | ± 0.75 dB (typical) |
| | 100 MHz to 12 GHz | ± 1.25 dB |
| | 12 GHz to 15 GHz | ± 2.0 dB |
| | 15 GHz to 20 GHz | ± 1.5 dB |

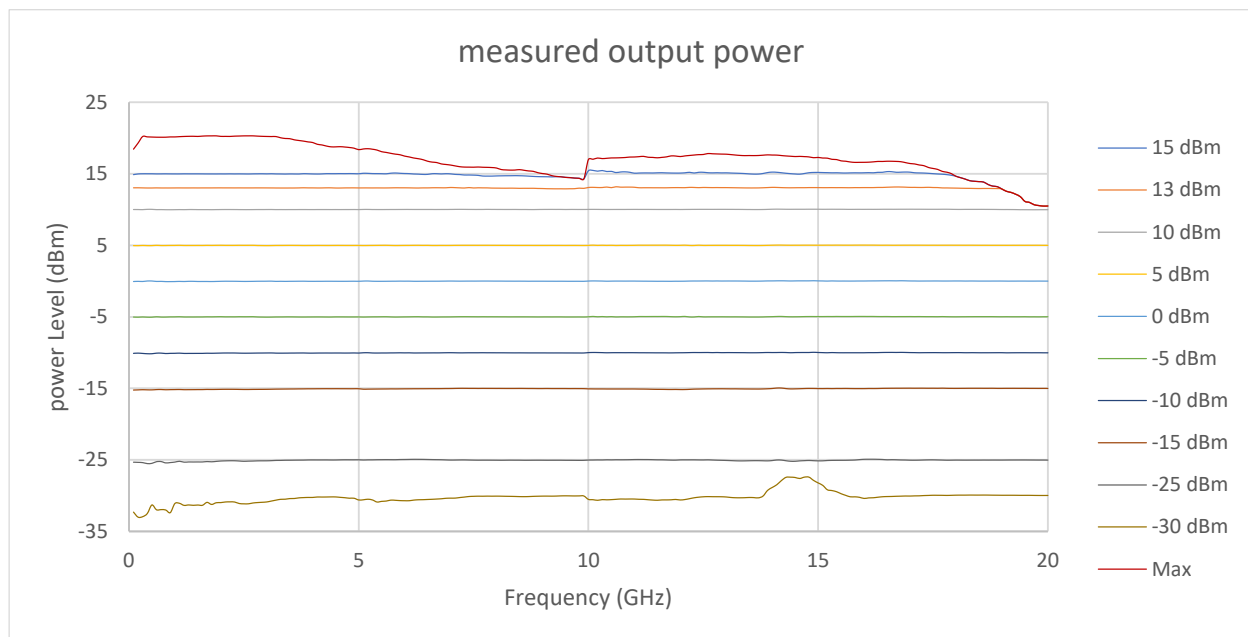

⁵ PXI: 27 ± 5 °C ambient. Modular: 40 ± 5 °C device temperature.

⁶ Leveled range implies that the set amplitude is maintained over the frequency band.

⁷ Maximum output is typical and does not guarantee that the value holds true for the frequency range. The minimum output level is < -20 dBm.

Output voltage standing wave ratio (VSWR)

| | |
|-------------------|---------------|
| 160 MHz to 10 GHz | < 2.0 typical |
| 10 GHz to 15 GHz | < 2.5 typical |
| 15 GHz to 20 GHz | < 1.8 typical |

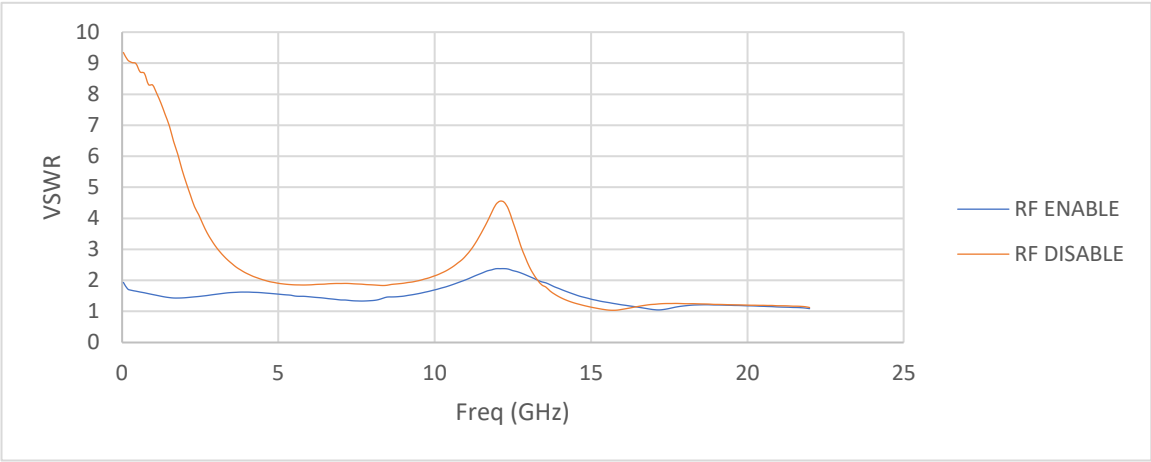

Pulse

| | |
|---------------------------|---------|
| On/Off ratio | ➤ 50 dB |
| Trigger propagation delay | 20 ns |
| On/Off to 0.1 dB Settling | 25 ns |

5. Port 1 Spectral Specifications⁸

Phase Noise (Normal loop gain, dBc/Hz)

| Offset | RF Frequency | | | | | | | |
|---------|--------------|------|-------|------|--------|------|--------|------|
| | 1 GHz | | 5 GHz | | 10 GHz | | 20 GHz | |
| | Typ | max | Typ | max | Typ | max | Typ | max |
| 100 | -100 | -79 | -86 | -66 | -80 | -74 | -74 | -68 |
| 1 kHz | -122 | -117 | -109 | -103 | -103 | -98 | -97 | -91 |
| 10 kHz | -136 | -131 | -123 | -117 | -117 | -112 | -111 | -106 |
| 100 kHz | -137 | -132 | -124 | -117 | -118 | -112 | -112 | -107 |
| 1 MHz | -133 | -130 | -121 | -117 | -115 | -110 | -110 | -106 |
| 10 MHz | -150 | -147 | -139 | -133 | -133 | -130 | -131 | -130 |
| Floor | -153 | -149 | -150 | -147 | -147 | -145 | -145 | -145 |

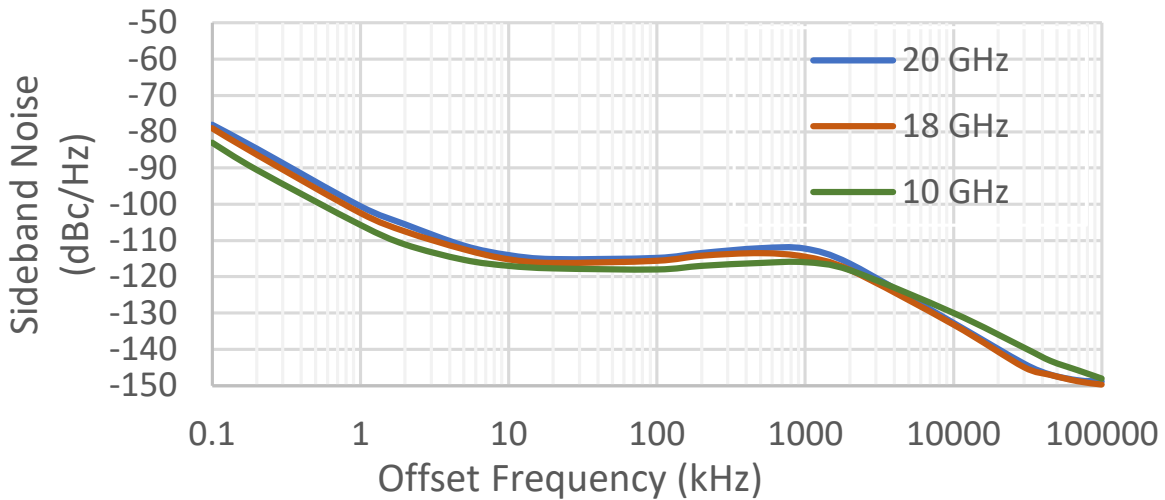

⁸ PXI: 27 ± 5 °C ambient. Modular: 40 ± 5 °C device temperature.

| | | |
|---------------------|----------------------|-------------------|
| Harmonics | 100 MHz to 400 MHz | < -10 dBc |
| | 400 MHz to 10 GHz | < -25 dBc |
| | 10.0 GHz to 20.0 GHz | < -20 dBc |
| Subharmonics | | < -80 dBc typical |
| | | < -70 dBc |

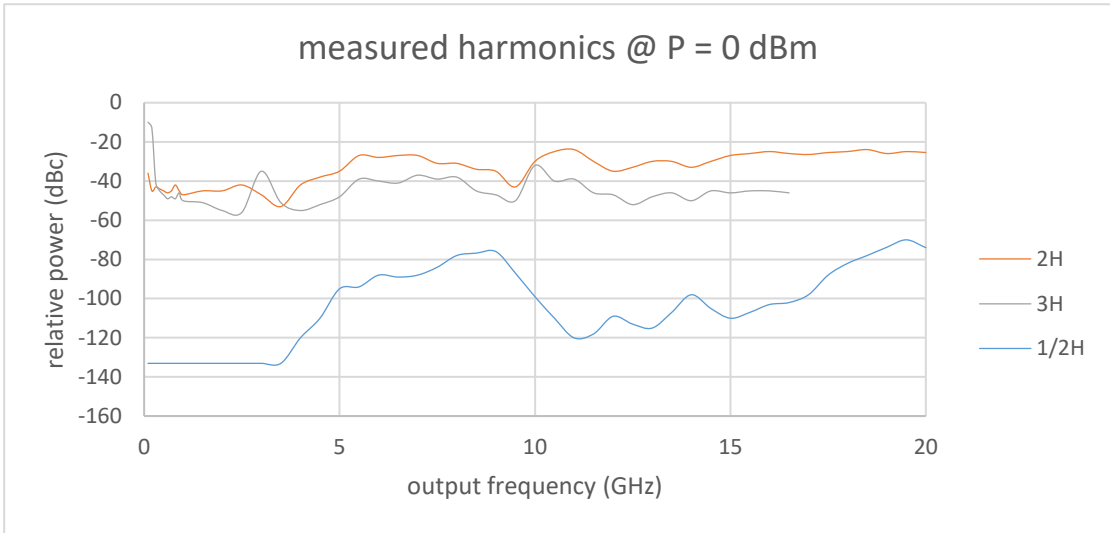

Nonharmonics

| Frequency | Close-in Spurs ⁹ | | Far-out Spurs ¹⁰ | |
|----------------------|-----------------------------|---------|-----------------------------|---------|
| | typical | max | typical | max |
| 100 MHz to 5.0 GHz | < -70 dBc | -55 dBc | < -70 dBc | -60 dBc |
| 5.0 GHz to 10.0 GHz | < -60 dBc | -50 dBc | < -65 dBc | 60 dBc |
| 10.0 GHz to 20.0 GHz | < -60 dBc | -45 dBc | < -65 dBc | -50 dBc |

⁹ < 10 MHz from center carrier frequency

¹⁰ > 10 MHz from center carrier frequency

6. Port 2 Specifications¹¹

| | | |
|----------------------------|--------------------|----------------|
| Frequency range | 100 MHz to 3.0 GHz | |
| Resolution | 25 MHz | |
| Harmonics | 100 MHz to 18 GHz | < - 12 dBc |
| Output power | Fixed | +5 dBm typical |
| Phase Noise @ 1 GHz | 1 kHz..... | -110 dBc/Hz |
| | 10 kHz..... | -118 dBc/Hz |
| | 100 kHz..... | -118 dBc/Hz |
| | 1 MHz..... | -142 dBc/Hz |
| | 10 MHz..... | -160 dBc/Hz |

¹¹ PXI: 27 ± 5 °C ambient. Modular: 42 ± 5 °C device temperature.

7. General Specifications

Environmental

| | | |
|---------------------------------------|---------|--|
| Internal Device Operating Temperature | SC5511B | -10°C to +75°C |
| Ambient temperature | SC5510B | -10°C to +55°C |
| Ambient Storage Temperature | | -40°C to +90°C |
| Operating Relative Humidity | | 10% to 90%, non-condensing |
| Storage Relative Humidity | | 5% to 90%, non-condensing |
| Operating Shock | | 30 g, half-sine pulse, 11 ms duration |
| Storage Shock | | 50 g, half-sine pulse, 11 ms duration |
| Operating Vibration | | 5 Hz to 500 Hz, 0.31 g _{rms} |
| Storage Vibration | | 5 Hz to 500 Hz, 2.46 g _{rms} |
| Altitude | | Up to 30,000 feet (de-rate max device temperature to 60°C) |

Physical

| | | |
|---------------------------------------|------------------|----------------------------|
| Dimensions (W x H x D, max envelope) | SC5511B | 3.7" x 0.75" x 5.75" |
| | SC5510B | Single PXI Slot |
| Weight | | 1.0 lb. |
| RF Output Connectors | | SMA |
| Reference Connectors | | SMA |
| PXI Backplane Clock Connector | SC5510B | MCX |
| RF Connector Nominal Impedance | | 50 Ω |
| Power and digital Interface Connector | SC5511B | TFM-115-01-L-D-RA |
| Communication Interface | | PXIe, USB and RS-232 / SPI |
| Input Voltage | SC5511B | 11 to 15 VDC |
| | SC5510B | 5V, 12V |
| Current | Peak (initial) | 2.7 A max @ 12V |
| | Steady (average) | 1.7 A @ 12V |
| Power Consumption | | 21 W max |

Electromagnetic Compatibility (EMC)

This product meets the requirements of the following EMC standards for electrical equipment for measurement, control, and laboratory use:

- EN 61326-1 (IEC 61326-1): Basic immunity
- EN 55011 (CISPR 11): Class A Radiated emissions
- EN 55011 (CISPR 11): Class A Conducted emissions
- EN 61000-4-2: Electrostatic Discharge
- EN 61000-4-3: Radiated Immunity
- EN 61000-4-6: Conducted Immunity
- FCC 15.109: Radiated emissions
- ICES-003: Class A emissions

CE

This product meets the essential requirements of applicable European Directive:

- 2014/30/EU; Electromagnetic Compatibility Directive (EMC)

Warranty 3 years on parts and labor on defects in materials or workmanship.

8. Revision Table

| Revision | Revision Date | Description |
|----------|---------------|-----------------------|
| 2.0 | 05/01/2023 | Document reformatted |
| 2.1 | 08/08/2024 | Updated block diagram |

